



M2D : Compact Curvilinear Array Loudspeaker



The M2D™ compact curvilinear array loudspeaker brings numerous advantages to mid-sized venues that require tight vertical pattern control with medium-to-long throw. Its operating frequency range is 60 Hz to 16 kHz, with maximum peak output of 136 dB SPL (each cabinet) at 1 meter.

The M2D is designed for implementing vertical curvilinear arrays of up to 16 cabinets with 1- to 7-degree splay between adjacent units. For maximum leeway in configuring systems, the M2D is fully compatible with other M Series models and many Concert Series and UltraSeries™ loudspeakers.

The M2D uses Meyer Sound's patented REM™ ribbon emulation manifold to couple a single Meyer Sound 4-inch diaphragm (1.5-inch exit) compression driver to a 90-degree horn with constant-directivity horizontal coverage. REM controls the output of the compression driver and introduces it to the horn throat within a 3-inch path length, dramatically reducing distortion. The unique M2D horn design produces a coherent wave front that is characteristic of – but much more powerful than – a large ribbon driver. (Vertical coverage depends upon array length and curvature.)

The M2D's low-mid section comprises two Meyer Sound 10-inch cone drivers with lightweight neodymium magnet assemblies housed in a compact, vented trapezoidal enclosure. The M2D enclosure is constructed of multi-ply hardwood and coated with a textured black finish. Integral metal grilles protect the drivers. A weather-protected version with custom rain hood to protect the electronics is optionally available.

To assure the smoothest response in the midrange, the M2D incorporates a complex crossover design; at the lowest frequencies, both 10-inch drivers combine to reproduce powerful, coherent bass, while in the mid frequencies the crossover feeds only one of the two drivers. This technique eliminates interference between the drivers that would otherwise occur at shorter wavelengths, and maintains optimal polar and frequency response characteristics.

The self-powered, biamplified M2D incorporates a complementary MOSFET power amplifier with 700 watts burst capability, together with active crossover and optimized frequency and phase response correction circuitry. Its Intelligent AC™ system performs automatic voltage selec-

tion, allowing the unit to accommodate mains voltages in the range of 90 to 265 V AC at 50 or 60 Hz and additionally provides EMI filtering, soft current turn-on and surge suppression. Integral peak and rms limiters protect the loudspeaker components from over-excursion and overheating. Phase-corrected active processing circuits help maintain excellent performance and reliability, and the high common-mode rejection of the laser-trimmed differential input permits long signal runs through a simple shielded twisted pair cable.

QuickFly® rigging, fitted as standard, employs entirely captive hardware and allows flying up to 16 cabinets with a 7:1 safety factor. The optional MG-2D multipurpose grid allows loudspeakers to be flown or ground stacked. The M2D features Meyer Sound's RMS™ remote monitoring system, which allows the full range of operating parameters to be monitored continuously over a network using a Windows computer.

The companion M2D-Sub compact subwoofer is also available to provide low-frequency enhancement and extend overall system power bandwidth and frequency response to 30 Hz.

FEATURES & BENEFITS

- Extremely high power-to-size ratio
- Ideal system for mid-sized applications, or as downfill in larger venues
- Optimized line array behavior provides consistent response over long throws
- Multiple vertical line arrays may be splayed horizontally to broaden coverage
- Self-powered for simplified setup and increased reliability
- Seamless integration with other M Series models

APPLICATIONS

- Concert halls, nightclubs and houses of worship
- Theatrical sound reinforcement
- Portable and installed audio-visual systems

ARCHITECT SPECIFICATIONS

The loudspeaker shall be a self-powered, full-range unit for deployment in line array systems. The low-frequency transducers shall consist of two 10-inch cone drivers with 2-inch voice coils rated to handle 400 AES watts* each. The high-frequency transducer shall be one 4-inch diaphragm (1.5-inch exit) compression driver, rated to handle 250 AES watts, coupled via a custom REM manifold to a 90° horizontal constant directivity horn.

The loudspeaker shall incorporate internal processing electronics and a two-channel amplifier. Processing functions shall include equalization, phase correction, driver protection, and signal division for the high- and low-frequency sections. The crossover point (equal sound pressure levels between high- and low-frequency transducers) shall be 575 Hz. An additional low-frequency crossover shall cause the two low-frequency transducers to work in combination between 60 Hz and 350 Hz, with only one working between 350 Hz and 575 Hz, to maintain optimal polar response characteristics.

Each amplifier channel shall be class AB/bridged with complementary MOSFET output stages. Burst capability shall be 700 watts total with nominal 8-ohm load for the high-frequency channel and 2 ohms for the low-frequency channel. Distortion (THD, IM, TIM), unloaded, shall not exceed 0.02%. Protection circuits shall include peak and RMS limiters. The audio input shall be electronically balanced with a 10-kOhm input impedance and accept a nominal 0 dBV (1 V rms) signal (20 dBV to produce maximum SPL). Connectors shall be XLR (A-3) type male and female or VEAM. RF filtering shall be provided, and CMRR shall be greater than 50 dB (typically 80 dB, 50 – 500 Hz).

Performance specifications for a typical production unit shall be as follows, measured at 1/3 octave resolution: Operating frequency range shall be 60 Hz to 16 kHz. Phase response shall be $\pm 45^\circ$ from 650 Hz to 12 kHz. Maximum peak SPL shall be 136 dB at 1 meter with music. Beamwidth shall be 90°. Vertical coverage in multi-cabinet arrays shall be dependent on system configuration.

The internal power supply shall perform automatic voltage selection, EMI filtering, soft current turn-on and surge suppression. Powering requirements shall be nominal 100, 110 or 230 V AC line current at 50 or 60 Hz. UL and CE operating voltage range shall be 100 to 240 V AC.

Maximum peak current draw during burst shall be 5.8 A at 115 V AC, 2.9 A at 230 V AC and 6.7 A at 100 V AC. Current inrush during soft turn-on shall not exceed 9 A at 115 V AC. AC power connectors shall be locking PowerCon or VEAM all-in-one multi-pin connector.

The loudspeaker system shall incorporate the electronics module for Meyer Sound's RMS remote monitoring and control system.

All loudspeaker components shall be mounted in an enclosure constructed of multi-ply hardwood with a hard black textured finish. The front protective grille shall be powder-coated, hex stamped steel.

Dimensions shall be 39.00" wide x 12.12" high x 17.47" deep (991 mm x 308 mm x 444 mm). Weight shall be 116 lbs (52.62 kg).

The loudspeaker shall be the Meyer Sound M2D.

*Loudspeaker driven with a band-limited noise signal with 6 dB peak-to-average ratio for a period of two hours.

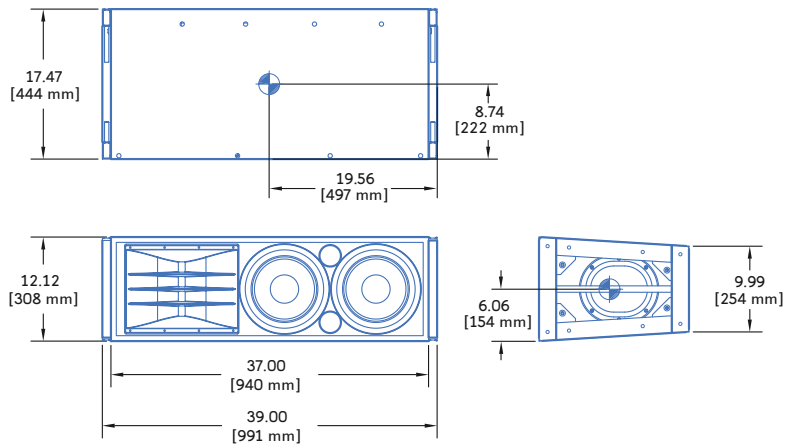

Dimensions	39.00" w x 12.12" h x 17.47" d (991 mm x 308 mm x 444 mm)
Weight	116 lbs (52.62 kg); shipping: 130 lbs (58.97 kg)
Enclosure	Multi-ply hardwood
Finish	Black textured
Protective Grille	Powder-coated hex stamped steel
Rigging	Patented QuickFly MRF-2D rigging frame with integral CamLinks™, rear connecting bars and captive quick-release pins

ABOUT THE VERTICAL DIRECTIVITY PLOTS

The color images accompanying the upper diagram on the facing page are sound intensity plots made using the Meyer Sound MAPP Online® acoustical prediction program, a unique and highly accurate visualization tool for professional sound system designers.

Using an Internet-connected personal computer, the designer specifies Meyer Sound loudspeaker models, their locations, how they are aimed and, optionally, the locations and composition of walls. This information travels over the Internet to a powerful server computer at Meyer Sound headquarters in Berkeley, Calif. Running a sophisticated algorithm and using highly accurate measured data that describe each loudspeaker's directional characteristics, the server predicts the sound field that the loudspeakers will produce, forms a color representation, and sends the result back for the designer's computer to display.

In these sound field plots, the color spectrum is used to represent levels of sound intensity, with red being the loudest and blue the softest, as shown in the scale to the immediate right. These examples illustrate coverage characteristics for an array whose splay angles have been tailored to the actual venue whose section view is superimposed on the MAPP Online plots.

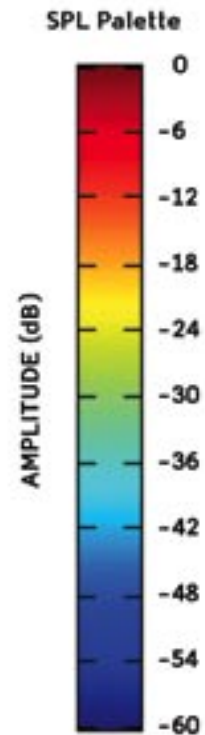

M2D VERTICAL SPLAY AND COVERAGE

These illustrations show how the splay between adjacent cabinets in an M2D array may be adjusted to tailor coverage for a specific venue. The MAPP Online plots on the right illustrate the vertical directivity characteristics of the array on the left, with a section view of the venue superimposed.

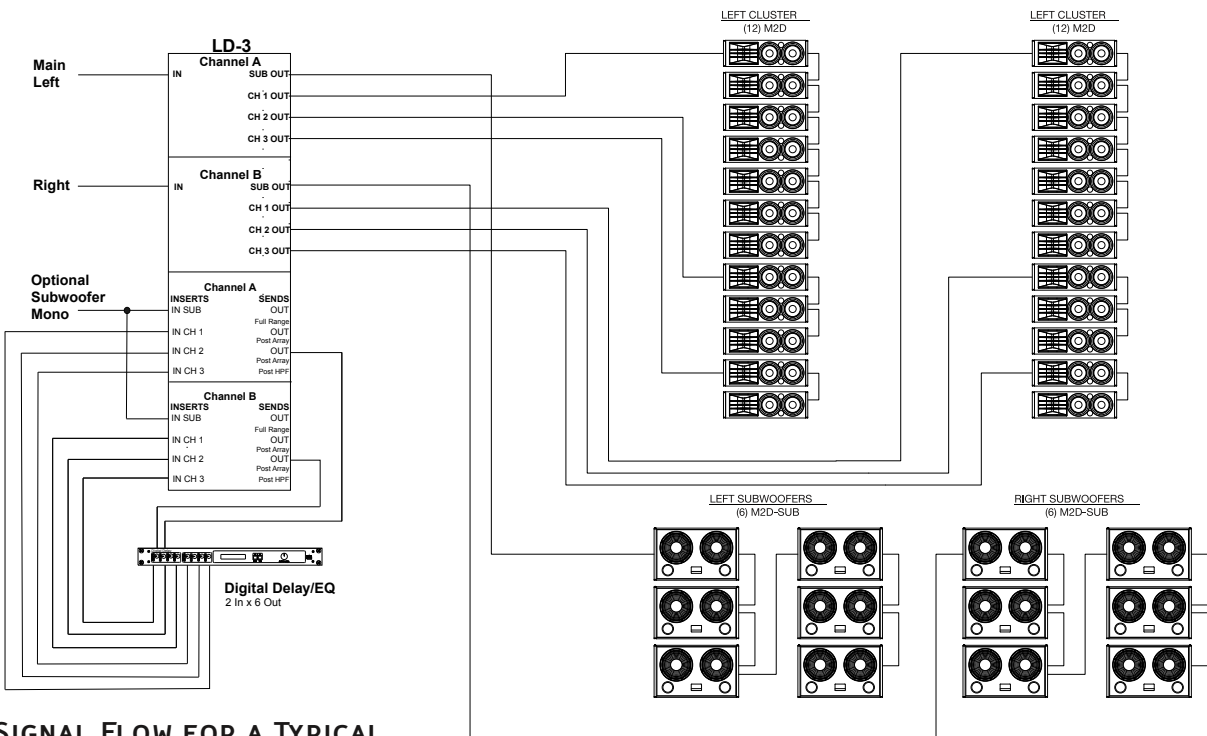
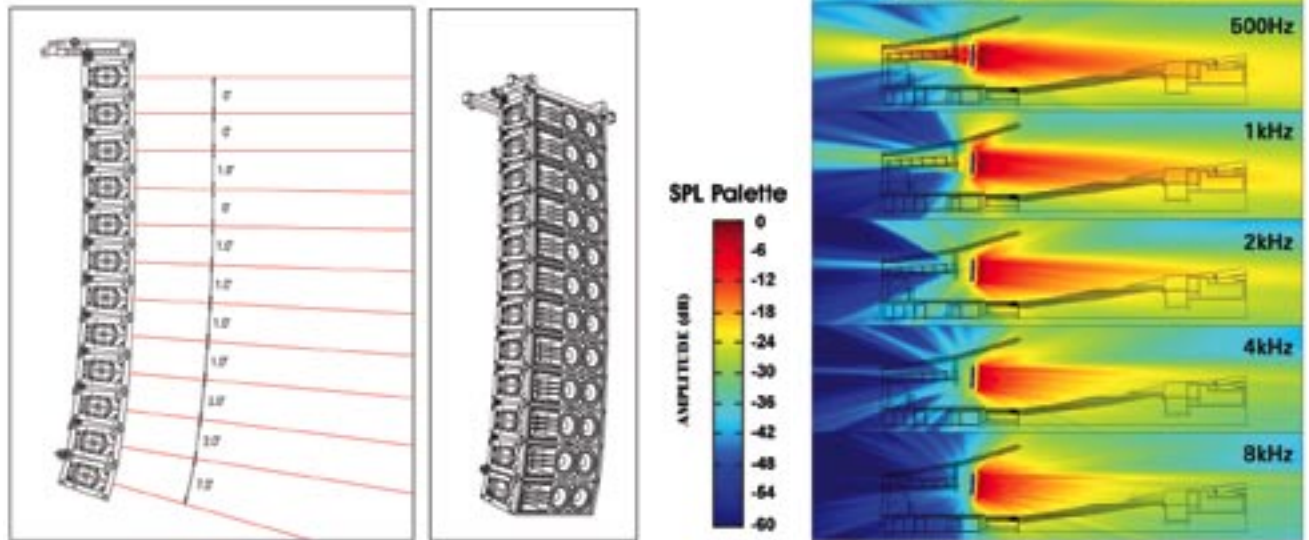

SIGNAL FLOW FOR A TYPICAL INTEGRATED REINFORCEMENT SYSTEM

Because the M2D is compatible with most other Meyer Sound reinforcement loudspeakers, sound designers have maximum freedom to customize systems for their needs. This block diagram illustrates the signal flow for a typical integrated sound reinforcement system using 12 M2Ds per side for the main arrays.

M2D SPECIFICATIONS

ACOUSTICAL¹		
Operating Frequency Range ²	60 Hz – 16 kHz	
Frequency Response ³	70 Hz – 14 kHz ±4 dB	
Phase Response	650 Hz – 12 kHz ±45°	
Maximum Peak SPL ⁴	136 dB	
Dynamic Range	>110 dB	
COVERAGE		
Horizontal Coverage	90°	
Vertical Coverage	Varies, depending on array length and configuration	
CROSSOVER		
	575 Hz ⁵	
TRANSDUCERS		
Low/Mid Frequency ⁷	Two 10" cone drivers with neodymium magnets Nominal impedance: 4 Ω Voice coil size: 2" Power-handling capability: 400 W (AES) ⁶	
High Frequency ⁸	One 4" compression driver Nominal impedance: 8 Ω Voice coil size: 4" Diaphragm size: 4" Exit size: 1.5" Power-handling capability: 250 W (AES) ⁶	
AUDIO INPUT		
Type	Differential, electronically balanced	
Maximum Common Mode Range	±15 V DC, clamped to earth for voltage transient protection	
Connectors	Female XLR input with male XLR loop output or VEAM all-in-one connector (integrates AC, audio and network)	
Input Impedance	10 kΩ differential between pins 2 and 3	
Wiring	Pin 1: Chassis/earth through 220 kΩ, 1000 pF, 15 V clamp network to provide virtual ground lift at audio frequencies Pin 2: Signal + Pin 3: Signal – Case: Earth ground and chassis	
DC Blocking	Differential DC blocking up to max common mode voltage	
CMRR	>50 dB, typically 80 dB (50 Hz – 500 Hz)	
RF Filter	Common mode: 425 kHz Differential mode: 142 kHz	
TIM Filter	Integral to signal processing (<80 kHz)	
Nominal Input Sensitivity	0 dBV (1 V rms, 1.4 V pk) continuous average is typically the onset of limiting for pink noise and music	
Input Level	Audio source must be capable of producing a minimum of +20 dBV (10 V rms, 14 V pk) into 600 Ω in order to produce maximum peak SPL over the operating bandwidth of the loudspeaker	
AMPLIFIER		
Type	Two-channel complementary MOSFET output stages (class AB/bridged)	
Output Power	700 W ⁹	
THD, IM, TIM	<.02 %	
Load Capacity	2 Ω low channel, 8 Ω high channel	
Cooling	Convection; 24 V DC output for optional external fan	
AC POWER		
Connector	PowerCon or VEAM	
Voltage Selection	Automatic	
Safety Agency Rated Operating Range	100 V AC – 240 V AC; 50/60 Hz	
Turn-on and Turn-off Points ¹⁰	Continuous 90 V AC – 265 V AC; 50/60 Hz	
Current Draw:		
Idle Current	0.35 A rms (115 V AC); 0.35 A rms (230 V AC); 0.35 A rms (100 V AC)	
Max Long-Term Continuous Current (>10 sec)	3.1 A rms (115 V AC); 1.6 A rms (230 V AC); 3.6 A rms (100 V AC)	
Burst Current (<1 sec)	3.2 A rms (115 V AC); 1.6 A rms (230 V AC); 3.7 A rms (100 V AC)	
Ultimate Short-Term Peak Current Draw	5.8 A pk (115 V AC); 2.9 A pk (230 V AC); 6.7 A pk (100 V AC)	
Inrush Current	9 A pk (115 V AC and 230 V AC); 8 A pk (100 V AC)	
RMS NETWORK		
	Equipped for two conductor twisted-pair network, reporting all operating parameters of amplifiers to system operator's host computer.	

NOTES:

- The low-frequency power response of the system will increase according to the length of the array.
- Recommended maximum operating frequency range. Response depends on loading conditions and room acoustics.
- Free field, measured with 1/3 octave frequency resolution at 4 meters.
- Measured with music at 1 meter.
- At this frequency, the mid- and high-frequency transducers produce equal sound pressure levels.
- Power handling is measured under AES standard conditions: transducer driven continuously for two hours with band-limited noise signal having a 6 dB peak-average ratio.
- To eliminate interference at short wavelengths, the two 10-inch cone drivers work in combination at low frequencies (60 Hz – 350 Hz). At mid frequencies (350 Hz – 575 Hz) only one cone driver is fed from the crossover to maintain optimal polar and frequency response characteristics.
- The driver is coupled to a constant-directivity horn through a proprietary acoustical manifold (REM).
- Amplifier wattage rating based on the maximum unclipped burst sine-wave rms voltage that the amplifier will produce into the nominal load impedance. Low channel 30 V rms (42 V pk) into 2 ohms; high channel 32 V rms (45 V pk) into 8 ohms.
- No automatic turn-off voltages. Voltages above 265 V AC are fuse protected but may cause permanent damage to the power supply. Voltages below 90 V AC may result in intermittent operation.

Made by Meyer Sound, Berkeley, CA, USA
European Office:
Meyer Sound Germany
GmbH
Carl-Zeiss-Strasse 13
58751 Pöln, Germany



M2D – 04.112.011.01 B

Copyright © 2004
Meyer Sound Laboratories Inc.
All rights reserved

MEYER SOUND LABORATORIES INC.
2832 San Pablo Avenue
Berkeley, CA 94702

T: +1 510 486.1166
F: +1 510 486.8356

info@meyersound.com
www.meyersound.com